

Assembly Instructions

Note: Do not tighten Fasteners until all bolts are started hand tight, all nuts are on ground side, or to center of wheelbarrow.

- 1) Insert Carriage "Bolt B" (4) thru Tub, Bottom Support, Handle, and Leg. Fasten with Flange "Nut B"
- 2) Insert Carriage "Bolt A" (2) thru Tub, and Tub Support. Fasten with Flange "Nut B"
- 3) Insert "Bolt D" (4) thru leg and leg support. Fasten with "Washer A" and Locking "Nut A"
- 4) Insert "Bolt C" (4) thru Foot and Leg. Fasten with "Washer A" and Locking "Nut A"
- 5) Insert "Bolt F" (2) thru Tub Support, Handle, and Axle Mount. Fasten with "Washer A" and Locking "Nut A"
- 6) Insert "Bolt E" (2) thru Handle, and Axle Mount. Fasten with "Washer A" and Locking "Nut A"
- 7) Insert Axle thru both Axle mounts, put a Wheel and "Washer B" on each side and insert "Pin" into Axle and bend pin over.
- 8) Insert "Bolt E" (2) thru Nose Piece and Handle. Fasten with "Washer A" and Locking "Nut A"
- 9) Insert "Bolt F" (2) thru Nose Piece, Handle and Tub Support. Fasten with "Washer A" and Locking "Nut A"
- 10) Final tighten all fasteners

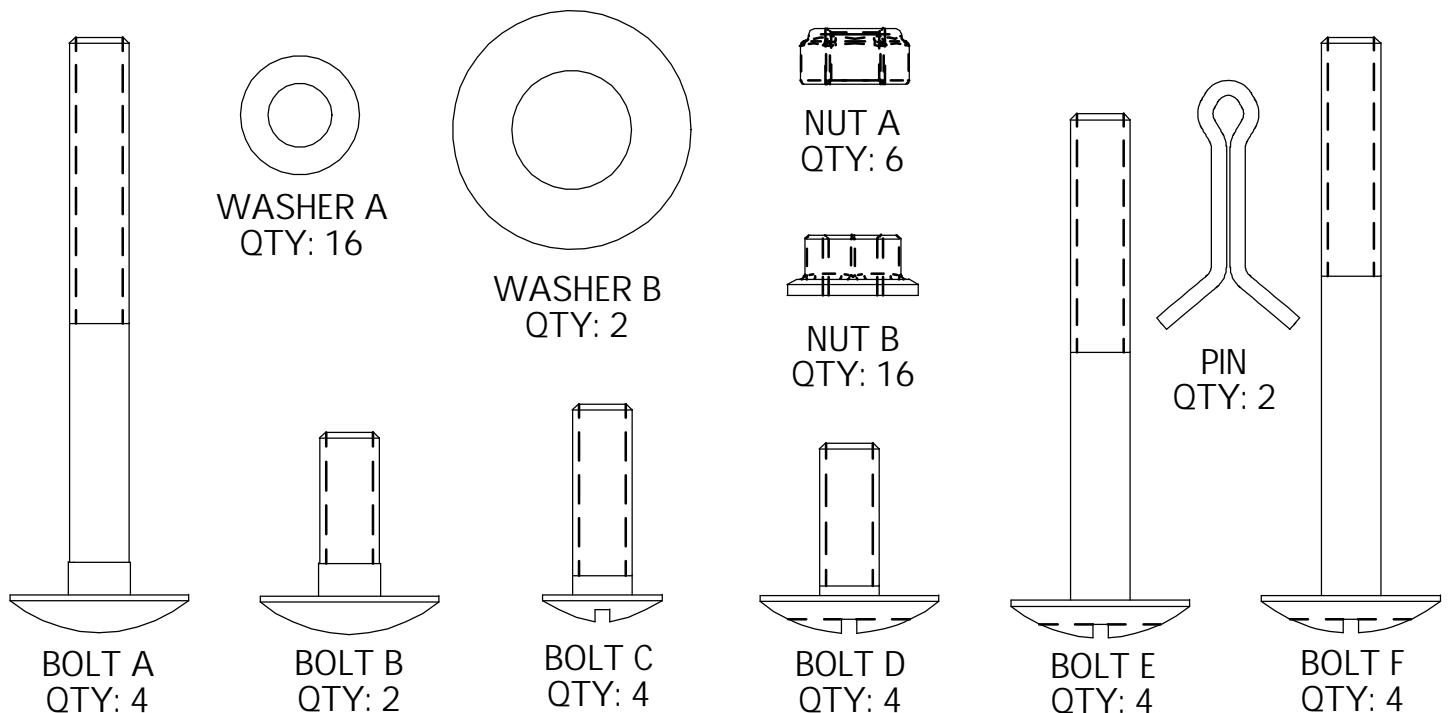

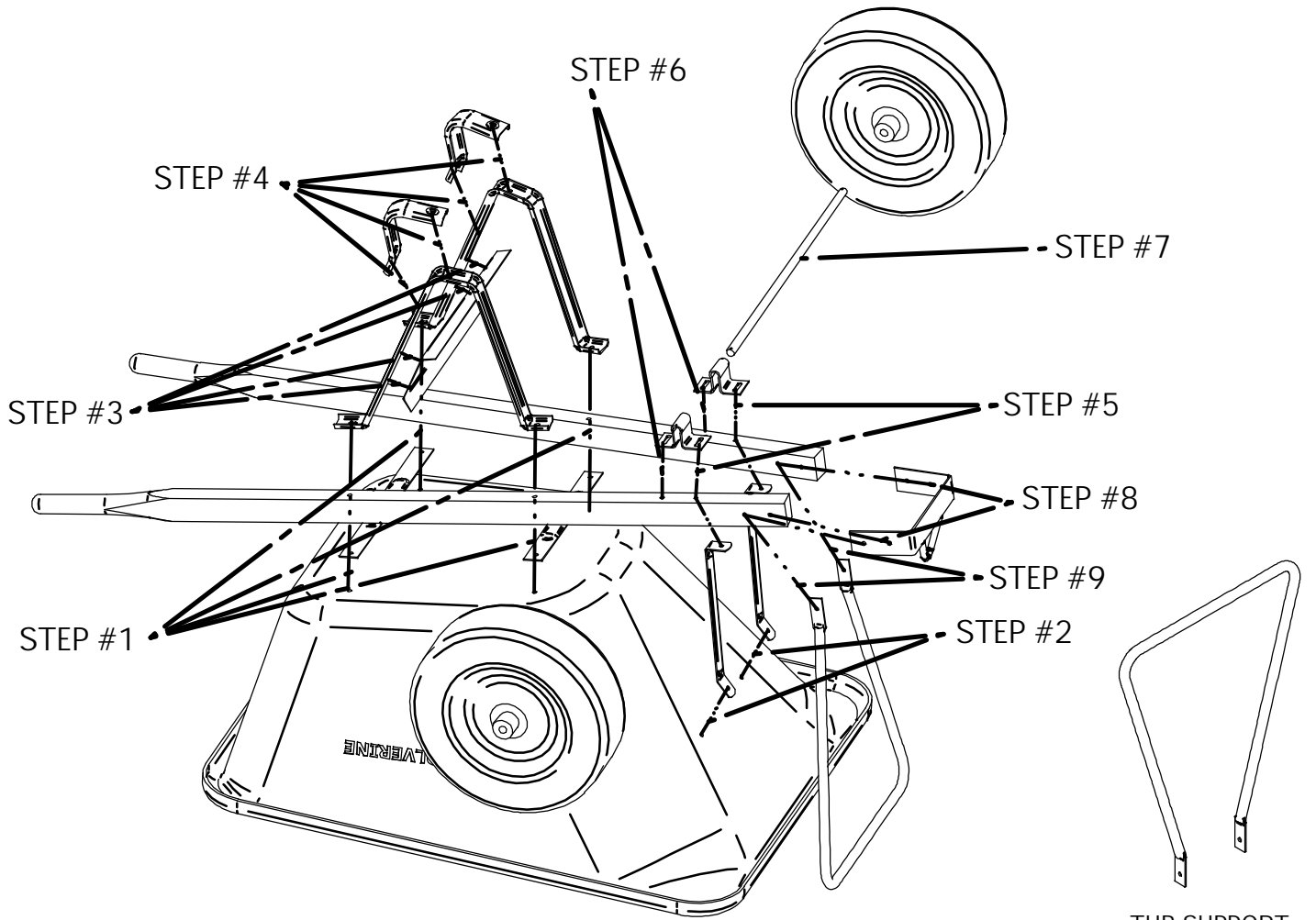

TUB SUPPORT
QTY: 1

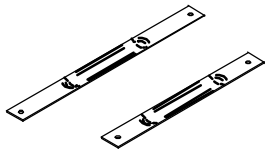

BOTTOM SUPPORTS
QTY: 1 LONG
QTY: 1 SHORT



TUB SUPPORT
QTY: 2

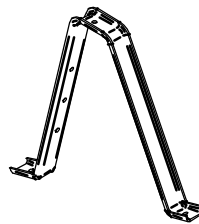

LEG
QTY: 2

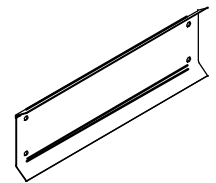

LEG SUPPORT
QTY: 1



FOOT
QTY: 2

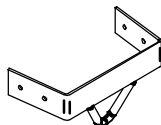

NOSE PIECE
QTY: 1



AXLE MOUNT
QTY: 2

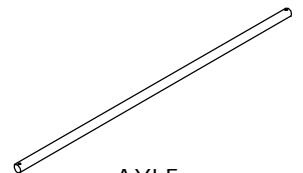

AXLE
QTY: 1



www.wolverinehandtools.com

Wolverine Products

494 East 64th Street
Holland, Michigan 49423
Phone: 1-800-787-3562

info@surelocedging.com